

SRMT/SRMF-9-350

SRMT series mounts are designed to provide efficient isolation from critical vibrations and all-directional restraint from vertical and horizontal forces, as well as from forces due to seismic activities and high wind loads.

Recommended for:

HVAC equipment, fan air circulation systems, compressors, pumps, chillers, shakers-screens, material and liquid processing equipment, and applications where low frequency isolation is required.

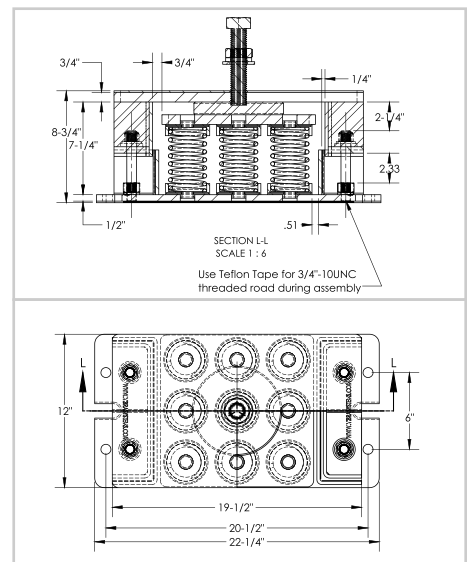

Features:

- ✓ All springs at rated loads have 50% additional travel to solid load.
- ✓ All mounts' elements are safe at solid load.
- ✓ Safety Factor for seismic mounts - maximum load is 50% of solid load.
- ✓ Recommended load range: from 50% of maximum load to maximum load.
- ✓ Zinc plates housings and springs provide good corrosion resistance.
- ✓ Elastomer spring base cap provides better vibration isolation, load distribution and noise reduction.
- ✓ Springs are color coded and easily replaceable.
- ✓ Rugged welded steel housing designed to withstand seismic and high wind forces.
- ✓ Anti-skid rubber acoustical pad.

Model	Maximum Load (lbs)	Deflection at Maximum Load (in)	Solid Load (lbs)	Deflection at Solid Load (in)	Spring Colour
SRMT-9-350		Spring - 3" dia. x 5" lg.		2" deflection	
SRMT-9-350	562	1.60	1,125	3.00	Red
SRMT-9-352	1,080	1.25	2,160	2.50	Yellow
SRMT-9-354	1,687	1.16	3,375	2.19	Purple
SRMT-9-356	3,937	1.08	7,875	2.10	Black
SRMT-9-358	7,650	1.13	15,300	2.10	Orange
SRMT-9D-350		Insert Spring - 2" dia. x 5" lg.		2" deflection	
SRMT-9D-358-144	11,250	1.25	22,500	2.10	Orange & Brown
SRMT-9D-358-146	13,500	1.09	27,000	2.00	Orange & Yellow
SRMT-9D-358-148	15,750	1.08	31,500	1.9	Orange & Green

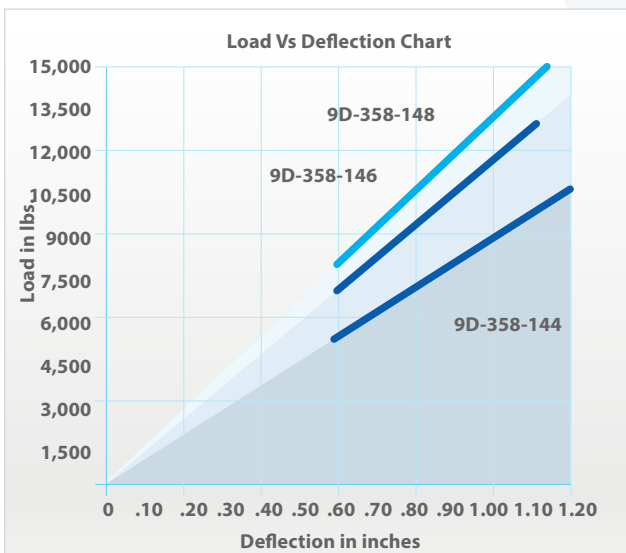
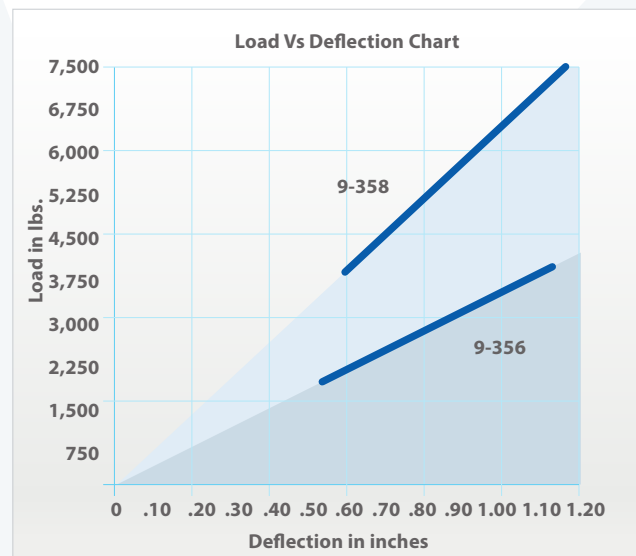
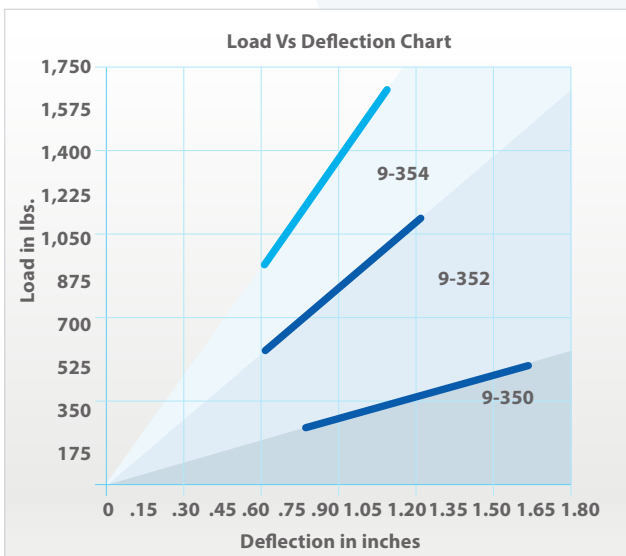

NOTE:

SRMF-9-350 & SRMF-9D-350

SRMF is a flat top model with inside levelling adjustment feature. All loads, deflections and technical data are the same as in SRMT.

INSTALLATION INSTRUCTIONS FOR SEISMIC RESTRAINED MOUNTS

For Models : SRMT-1-350; SRMT-2-350; SRMT-4-350; SRMT-9-350 and SRMT-15-350 .

1. Check each isolator's model number against the information in the packing slip, before beginning installation.
2. Secure isolators to the equipment support structure - concrete foundation or metal frame, according to the equipment base's drawing for the locations of the mounting holes.
 - If the equipment is installed on a concrete foundation, seismically rated concrete anchors and follow general anchor installation instructions with the required torque value on the anchor's nuts.
 - If the equipment is installed on a metal base, use grade 5 or better hardware to secure all isolators to the support base.
3. Do not tighten up the anchor's washers and nuts until the equipment is installed onto all of the isolators and the central bolts' threaded holes on the top metal isolators' plates line up with the holes in the equipment base.
4. Use a forklift, crane, or any other certified lifting machines to raise equipment to be installed. Slowly lower the equipment onto the isolators and make sure that the equipment base's holes perfectly align with the threaded holes on the top place of the isolators, and let equipment sit on all of the isolators.
5. Make sure that the central bolts of the isolators properly fit through the holes in the base of the equipment into threaded holes on the top plates of the isolators .Central bolts must have flat washer, lock washer, and hexagon nuts underneath the head of the bolts.
6. Tighten up all of the anchor bolts nuts using a torque wrench with the required torque value to secure the isolator's bases to the foundation.
7. When the equipment is loaded on all of the isolators, the springs of the isolators will be compressed under the load according to the Load vs. Deflection chart for this spring model. The left and right inside channels will slide down along the outside channels of the isolator's base under the weight of the equipment.
8. Turn all central bolts down clockwise until they touch the springs' metal bearing plates of the isolators, and proceed with leveling according to the standard leveling instructions for machinery installation. After the leveling is done, run down the central bolts' lock nuts and secure the equipment to the top plate of the isolator.
9. Adjust the lock nuts on the down side to allow a free movement of the installed equipment at all mounting points, with a minimum gap of 1/8". All side lock nuts must have plastic inserts to prevent them from moving on the threaded rods due to vibration.

Maximum leveling adjustments for all models is – 1/2". Use shims if/when required.

INSTALLATION INSTRUCTIONS FOR SEISMIC RESTRAINED MOUNTS

For Models : SRMF-1-350; SRMF-2-350; SRMF-4-350; SRMF-9-350 and SRMF-15-350 .

1. Check each isolator's model number against the information in the packaging slip, before beginning installation.
2. Secure the isolators to the equipment support structure - concrete foundation or metal, according to the equipment base's drawings for the locations of the mounting holes.
 - If the equipment is installed on a concrete foundation, use seismically rated concrete anchors and follow the general anchor installation instructions with the required torque value on the anchor's nuts.
 - If the equipment is installed on a metal base, use grade 5 or better hardware to secure all isolators to the support base.
3. Do not install the anchor's washers/nuts until the equipment is installed on all of the isolators' flat tops.
4. Use a forklift, crane, or any other certified lifting machines to raise the equipment being installed. Slowly lower the equipment onto the isolators and make sure that the flat top plates of the isolators are under the equipment base's mounting points.
5. Make sure that the flat tops of all isolators are properly secured to the equipment bases by bolting them together or by welding the isolators' flat top plates to the equipment bases.
6. Tighten all of the anchor bolts' nuts using a torque wrench with the required torque value to secure the isolator's bases to the foundation.
7. When the equipment is loaded on all of the isolators, the springs of the isolators will be compressed under the load according to the Load vs Deflection chart for this spring model. The left and right inside channels will slide down along the outside channels of the isolator's base under the weight of the equipment.
8. Proceed with leveling by turning the head of the bolt, located between the flat top plate and the spring's top metal bearing plate, according to standard leveling instructions for machinery installation. When the leveling is done, use a lock nut under the leveling bolt's hexagon head to lock the leveled position by tightening it to the spring bearing plate.
9. Adjust the down side lock nuts to allow a free movement of the installed equipment at all mounting points, with a minimum gap of 1/8" between the nuts, flat, and rubber washers on top of the inside channel's horizontal cross plate.
10. All of the side lock nuts have plastic inserts to prevent them from moving on the threaded rods due to vibration.

Maximum leveling for all model is – 1/2"; Use shims if/when required.