

2

1

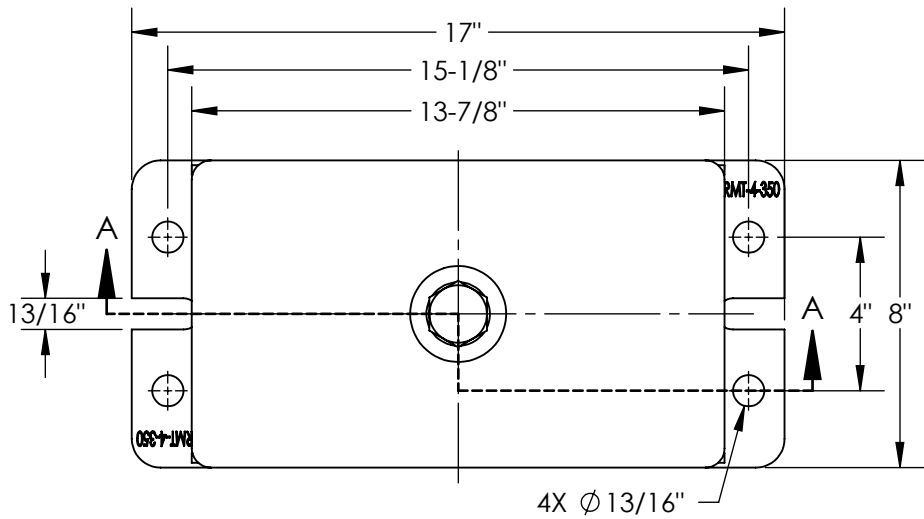

Model	Maximum Load (lbs)	Deflection at Maximum Load (in)	Solid Load (lbs)	Deflection at Solid Load (in)	Spring Rate (lbs/in)	Spring Color
SRMT-4-350	320	2.00	480	3.00	160	Red
SRMT-4-352	640	1.67	960	2.50	384	Yellow
SRMT-4-354	1,000	1.53	1,500	2.30	652	Purple
SRMT-4-354-142	1,600	1.53	2,400	2.30	1,044	Purple/Blue
SRMT-4-356	2,400	1.50	3,600	2.25	1,600	Black
SRMT-4-356-142	3,200	1.50	4,800	2.25	2,132	Black/Blue
SRMT-4-358	4,800	1.33	7,200	2.00	3,600	Orange
SRMT-4-358-142	5,320	1.33	7,980	2.00	3,992	Orange/Blue
SRMT-4-358-144	6,000	1.33	9,000	2.00	4,500	Orange/Brown
SRMT-4-358-146	7,200	1.33	10,800	2.00	5,400	Orange/Yellow
SRMT-4-358-148	8,800	1.33	13,200	2.00	6,600	Orange/Green

B

B

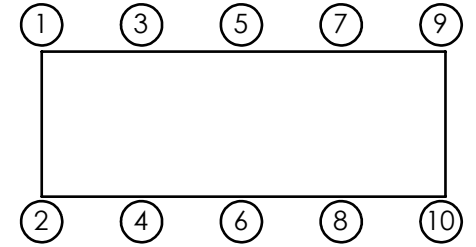
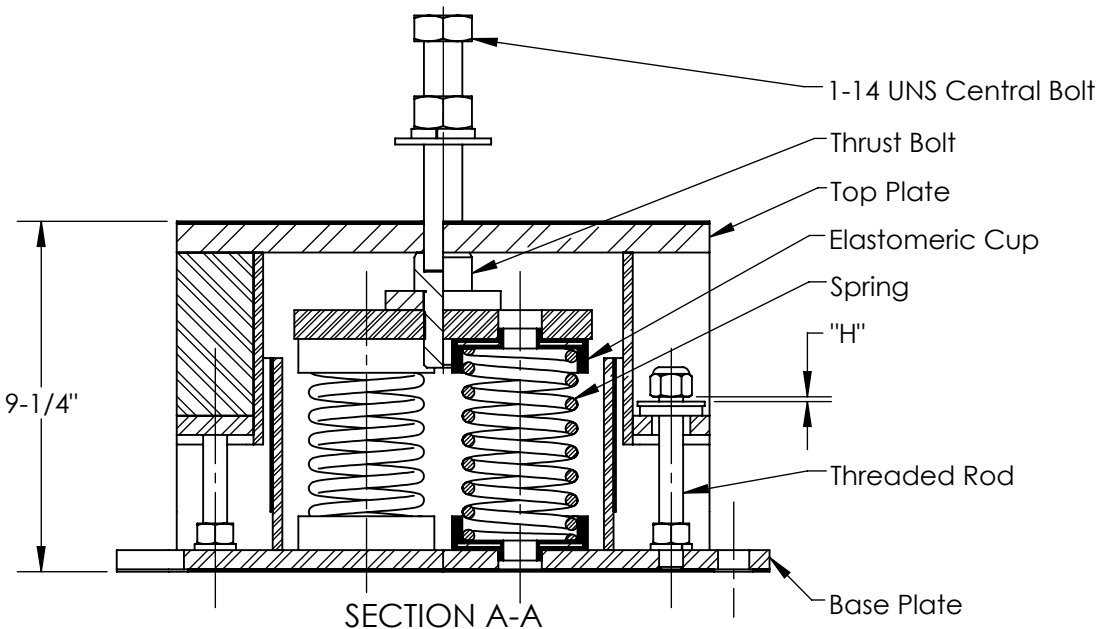

A

A

- Notes:**
- All dimensions are in inches, interpret per ANSI Y14.
  - Standard finish: Housing - Zinc Bright Plating; Spring - Zinc Bright Plating (Color: see table); Hardware - Zinc-electroplate.
  - All springs at maximum loads have 50% additional travel to solid load.
  - Safety factor will accommodate 50% extra load from maximum load.
  - Spring: 3" Outside diameter x 5" Free Length - 2" Deflection.
  - Insert Spring: 2" Outside diameter x 5" Free Length - 2" Deflection.

Isolator Selections			
Pos 1		Pos 2	
Pos 3		Pos 4	
Pos 5		Pos 6	
Pos 7		Pos 8	
Pos 9		Pos 10	

**VibraSystems Inc**  
 www.vibrasystems.com  
 email: info@vibrasystems.com

**INSTALLATION INSTRUCTIONS**

SCALE: None	MODEL: SRMT-4-350	SHEET 1 OF 2	REV A
-------------	-------------------	--------------	-------

2

1

1. Check each isolator's model number ("A") against the information on the packing slip, before beginning installation.
2. Secure the isolator to the equipment support structure - concrete foundation or metal frame, according to the equipment base's drawings for the locations of the mounting holes ("B").
  - 2.1. If the isolator is installed on a concrete foundation, use sets of seismically rated concrete anchors and follow the general anchor installation instructions with the required torque value on the anchor's nut.
  - 2.2. If the isolator is installed on a metal base, use grade 5 or better hardware to secure the isolator to the support base. Welding to steel base is permitted provided the weld achieves the required strength. Remove the rubber pad ("P") before welding.
  - 2.3. Vibrasystems Inc. recommends that all the isolators are installed on a level surface.

3. Use a forklift, crane or any other certified lifting machine to raise the equipment to be installed. Slowly lower the equipment on top of the isolators and make sure that equipment base's holes perfectly aligned with the threaded hole on the isolator's top plate ("D").
4. Make sure that the isolator's central bolt ("L") properly fit through the holes in the base of the equipment and into the threaded hole on the isolator's top plates ("D"). Central bolt must have a flat washer ("N"), a spring washer ("M"), and a hexagon nut ("K") underneath the head of the central bolt ("L"). Welding to steel base is permitted provided the weld achieves the required strength. Remove the rubber pad ("S") before welding.
5. When the equipment, which must be at the full operating weight, is placed onto the isolators, the isolator's spring will be compressed under the load according to the Load VS. Deflection chart for this isolator model. The inside channels ("E") will slide down along the outside channels ("I") of the isolator's base ("C") under the weight of the equipment.
6. Turn the central bolt ("L") clockwise until it touches the bottom of thrust bolt ("J").
7. Level each isolator in sequence by turning adjusting bolt ("L") a full clockwise turn at a time. Repeat this procedure on all isolators, one at a time. After the leveling is done, run down the lock nut ("K"), the spring washer ("M") and the flat washer ("N") to secure the equipment to the isolator's top plate ("D").
8. Adjust the lock nuts ("F") to allow a free movement of the installed equipment at all mounting points, with an allowed gap of 1/4" ("H") - see sheet 1 of 2. All side lock nuts ("F") have plastic inserts to prevent them from moving on the threaded rods ("O").
9. Installation is complete.

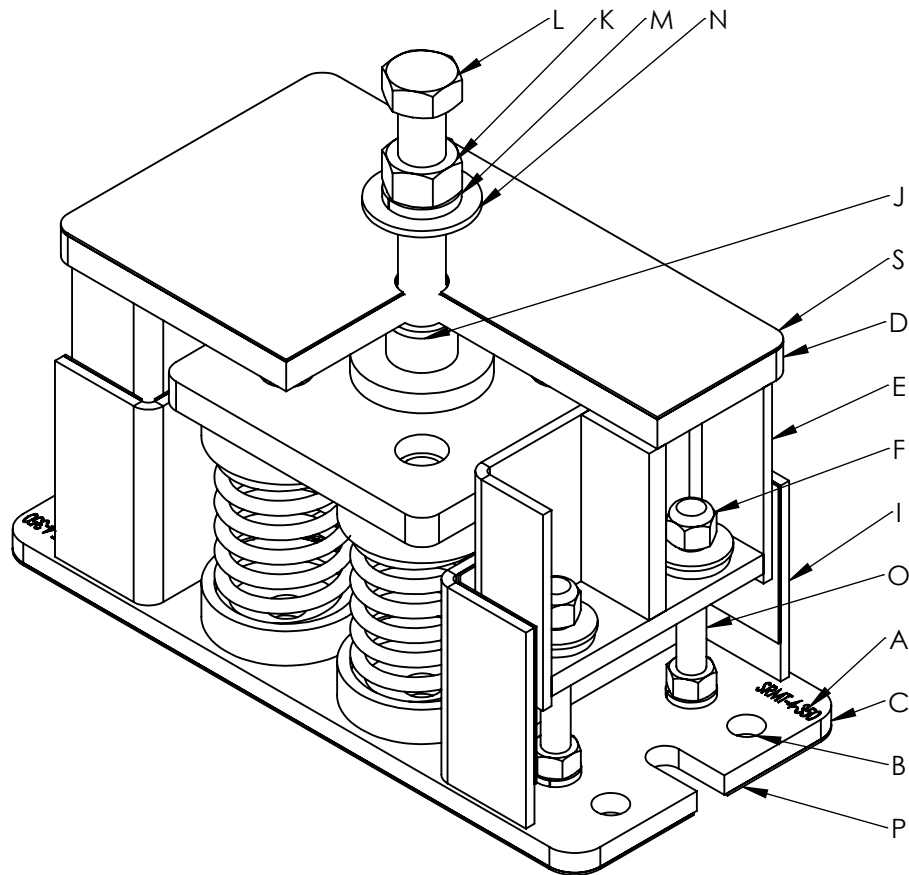

**VibraSystems Inc**  
 www.vibrasystems.com  
 email: info@vibrasystems.com

**INSTALLATION INSTRUCTIONS**

SCALE:	MODEL:	SHEET 2 OF 2	REV
None	SRMT-4-350		A