

2

1

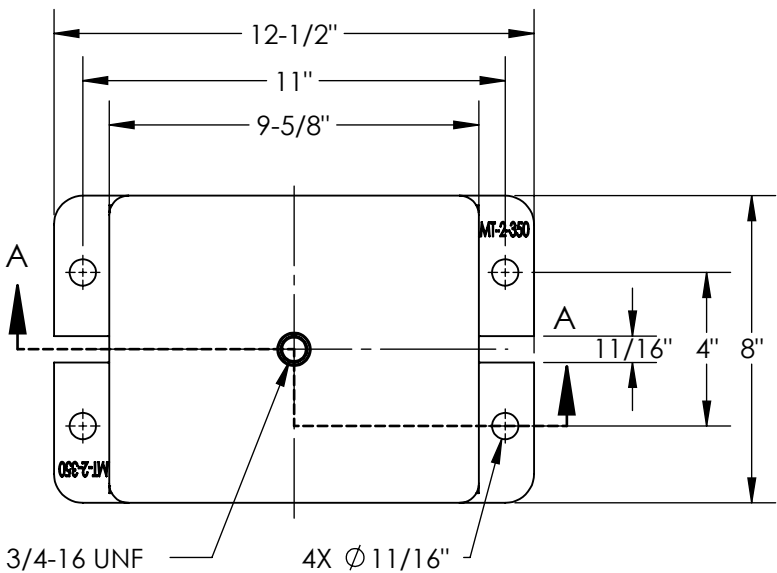

Model	Maximum Load (lbs)	Deflection at Maximum Load (in)	Solid Load (lbs)	Deflection at Solid Load (in)	Spring Rate (lbs/in)	Spring Color
SRMF-2-350	160	2.00	240	3.00	80	Red
SRMF-2-352	320	1.67	480	2.50	192	Yellow
SRMF-2-354	500	1.53	750	2.30	326	Purple
SRMF-2-354-142	800	1.53	1,200	2.30	522	Purple/Blue
SRMF-2-356	1,200	1.50	1,800	2.25	800	Black
SRMF-2-356-142	1,600	1.50	2,400	2.25	1,066	Black/Blue
SRMF-2-358	2,400	1.33	3,600	2.00	1,800	Orange
SRMF-2-358-142	2,660	1.33	3,990	2.00	1,996	Orange/Blue
SRMF-2-358-144	3,000	1.33	4,500	2.00	2,250	Orange/Brown
SRMF-2-358-146	3,600	1.33	5,400	2.00	2,700	Orange/Yellow
SRMF-2-358-148	4,400	1.33	6,600	2.00	3,300	Orange/Green

B

B

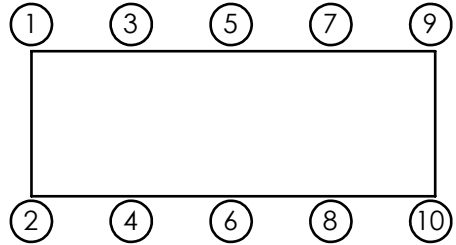
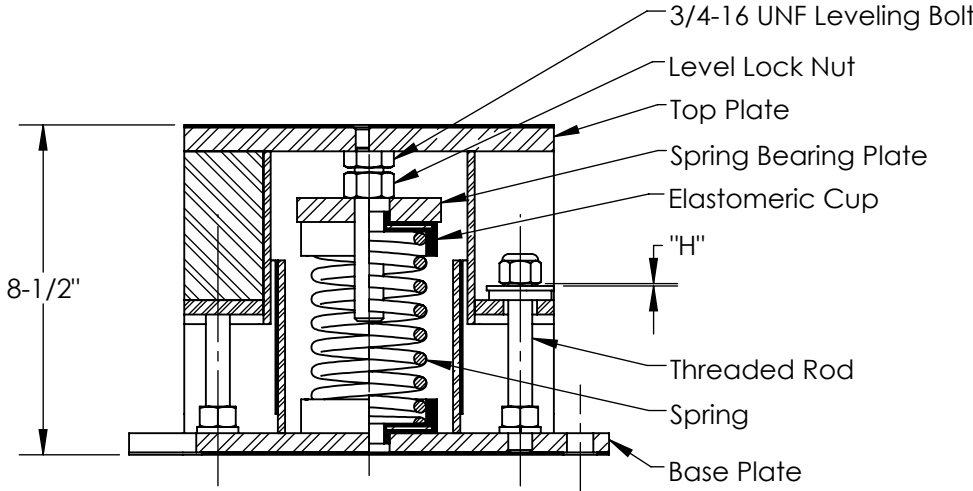

Isolator Selections			
Pos 1		Pos 2	
Pos 3		Pos 4	
Pos 5		Pos 6	
Pos 7		Pos 8	
Pos 9		Pos 10	

- Notes:**
- All dimensions are in inches, interpret per ANSI Y14.
  - Standard finish: Housing - Zinc Bright Plating; Spring - Zinc Bright Plating (Color: see table); Hardware - Zinc-electroplate.
  - All springs at maximum loads have 50% additional travel to solid load.
  - Safety factor will accommodate 50% extra load from maximum load.
  - Spring: 3" Outside diameter x 5" Free Length - 2" Deflection.
  - Insert Spring: 2" Outside diameter x 5" Free Length - 2" Deflection.

**VibraSystems Inc**

www.vibrasystems.com  
email: info@vibrasystems.com

**INSTALLATION INSTRUCTIONS**

SCALE: None	MODEL: SRMF-2-350	SHEET 1 OF 2	REV A
-------------	-------------------	--------------	-------

2

1

A

A

1. Check each isolator's model number ("A") against the information on the packing slip, before beginning installation.
2. Secure the isolator to the equipment support structure - concrete foundation or metal frame, according to the equipment base's drawings for the locations of the mounting holes ("B").
  - 2.1. If the isolator is installed on a concrete foundation, use sets of seismically rated concrete anchors and follow the general anchor installation instructions with the required torque value on the anchor's nut.
  - 2.2. If the isolator is installed on a metal base, use grade 5 or better hardware to secure the isolator to the support base. Welding to steel base is permitted provided the weld achieves the required strength. Remove the rubber pad ("P") before welding.
  - 2.3. Vibrasystems Inc. recommends that all the isolators are installed on a level surface.

3. Use a forklift, crane or any other certified lifting machine to raise the equipment to be installed. Slowly lower the equipment on top of the isolators and make sure that the equipment's base is perfectly aligned with the isolator's top plate ("D").
4. Make sure that the flat tops ("D") of all isolators are properly secured to the equipment's base by bolting or welding the isolator's flat top plates ("D") to the equipment's base. Welding to steel base is permitted provided the weld achieves the required strength. Remove the rubber pad ("S") before welding.
5. When the equipment, which must be at the full operating weight, is placed onto the isolator, the isolator's spring will be compressed under the load according to the Load VS. Deflection chart for this isolator model. The inside channels ("E") will slide down along the outside channels ("I") of the isolator's base ("C") under the weight of the equipment.
6. Level each isolator in sequence by turning the leveling bolt ("Q") a full counterclockwise turn at a time. Repeat this procedure on all isolators, one at a time. After the leveling is done, run down the level lock nut ("T") to lock the leveled position by tightening it to the spring bearing plate ("R").
7. Adjust the lock nuts ("F") to allow a free movement of the installed equipment at all mounting points, with an allowed gap of 1/4" ("H") - see sheet 1 of 2. All side lock nuts ("F") have plastic inserts to prevent them from moving on the threaded rods ("O").
8. Installation is complete.

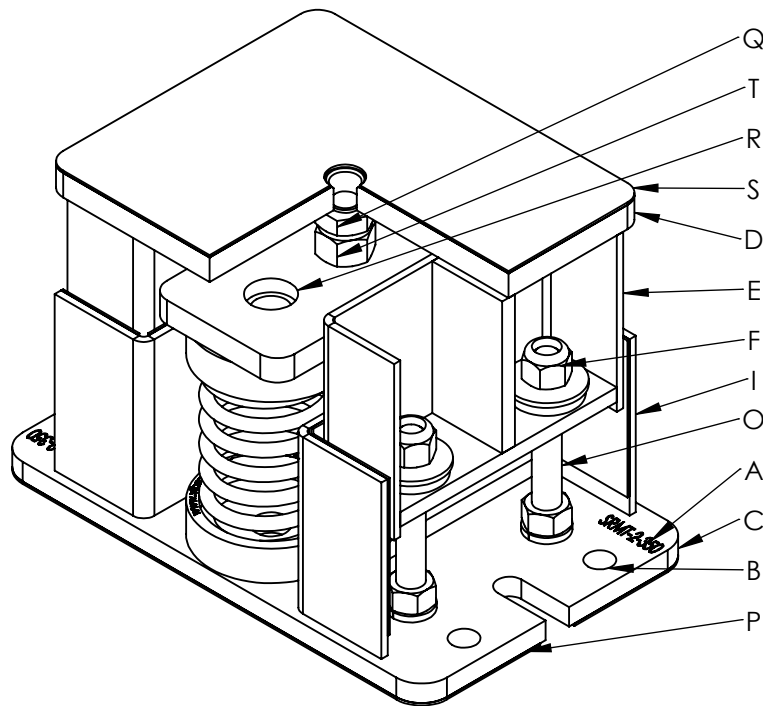

**VibraSystems Inc**  
 www.vibrasystems.com  
 email: info@vibrasystems.com

**INSTALLATION INSTRUCTIONS**

SCALE:	MODEL:	REV	
None	SRMF-2-350	A	
SHEET 2 OF 2			