

Installation Instructions for SRMF-1 (Flat Top)

1) Check each spring mount's model number before installation. Position each spring mount according to the submittal drawings or the equipment's load distribution chart.

2) Secure each spring mount to the equipment support structure or concrete foundation using the two mounting holes on the bottom frame. All bolts and anchor hardware must be a minimum of grade 5. If the engineering consulting agency or installation engineer recommends a higher grade of hardware, follow their recommendation. If spring mounts are welded in position, remove the rubber pad (RP) before welding (see figure 1).

3) Use a forklift, crane, or any other certified lifting machine to raise the equipment to be installed. Slowly lower the equipment on top of the spring mounts' top plates (TP) and ensure that the equipment's base is perfectly aligned with the spring mount's top plate's (TP) (see figure 1).

4) Raise the top restraint nuts (TRN) 3/16" as shown in Figure 1, Detail B.

5) Ensure that the top plates (TP) of all isolators are securely attached to the equipment base by bolting or welding.

6) Load each spring by turning all leveling bolts (LB) 1/2 turn at a time, adjusting each isolator in succession, as shown in Figure 1.

7) Once each spring's restraint plate (RP) has lifted off the bottom neoprene washer (BNW), stop adjusting that isolator, as shown in Figure 1, Detail B.

8) Continue steps 6 & 7 until all RP's have lifted off their bottom neoprene washers (BNW).

9) Adjust the top restraining nuts (TRN) and the bottom restrained nuts (BRN) together, ensuring that gap #1 and gap #2 have clearances of 1/8" to 3/16", as shown in Figure 1, Detail B.

10) Every spring mount **must** have clearances at both gap #1 and gap #2 after the installation is complete, as detailed in Figure 1, detail B.

11) After the equipment's leveling is complete, run down the lock nut (LN) and tighten it onto spring cup (SC), as shown in Figure 2.

Note: We recommend using professional millwrights for the installation.

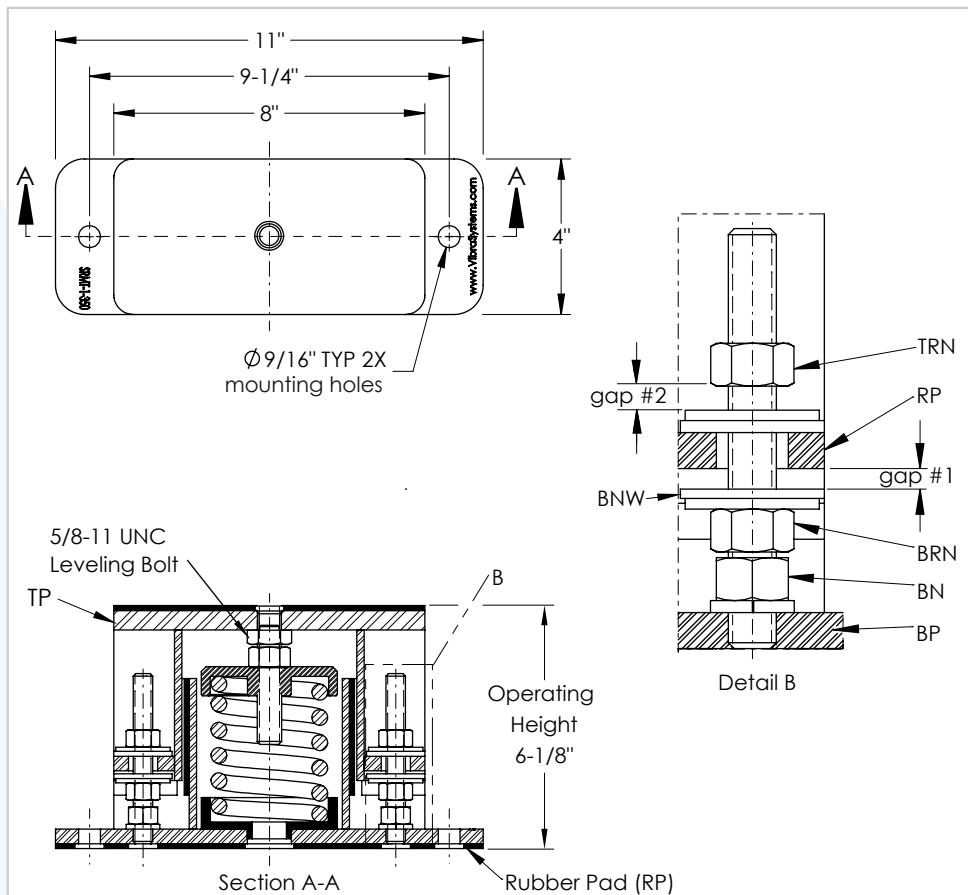
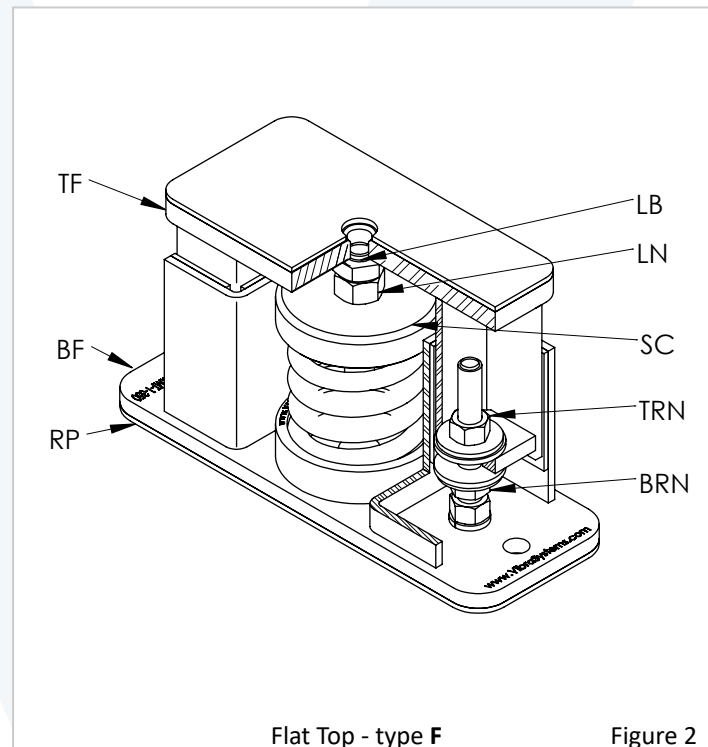

Figure 1



Flat Top - type F

Figure 2