

Ø 7/8" TYP 4X

1-14 UNS Leveling Bolt

Operating Height 11"

SECTION A-A

Model	Type "F" or "T"	Rated Load (lbs)	Deflec. @ Rated Load (in)	Spring Rate (lbs/in)	Max. G Rating	Spring Color	QTY
SMR-4-500		800	3	266.7		Black	
SMR-4-501		1,600	3	533.3		Blue	
SMR-4-502		2,400	3	800.0		Yellow	
SMR-4-503		3,200	3	1,066.7		Orange	
SMR-4-504		4,000	3	1,333.3		Red	
SMR-4-505		4,800	3	1,600.0		White	
SMR-4-506		6,000	3	2,000.0		Brown	
SMR-4-507		8,000	3	2,666.7		Green	
SMR-4-506-853		10,000	3	3,333.3		Brown/Grey	
SMR-4-509		12,000	3	4,000.0		Grey	
SMR-4-509-853		16,000	3	5,333.3		Grey/Grey	

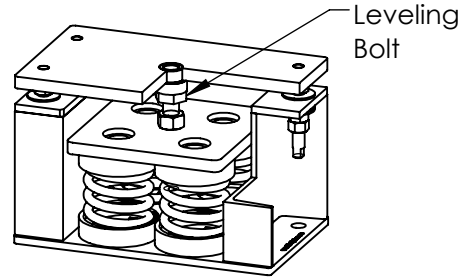

Type F

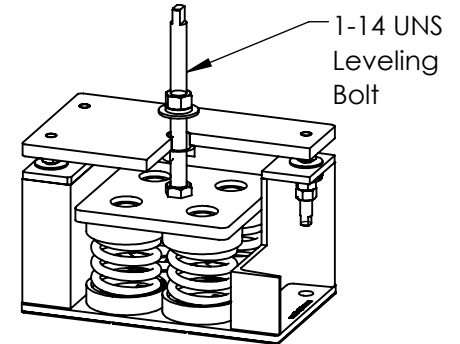

Type T

Notes:

- Standard finishing:
 - Housing: Hot-dip Galvanizing;
 - Springs: Powder Coating;
 - Hardware: Zinc-electroplating.
- All springs will accommodate 50% extra load from rated load to solid load.

Isolator Selections			
Pos 1		Pos 2	
Pos 3		Pos 4	
Pos 5		Pos 6	
Pos 7		Pos 8	
Pos 9		Pos 10	

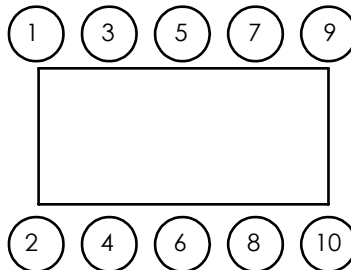

	NAME	DATE
DRAWN	R.D.	2023-05-23
APPR.	--	--
QUANTITY	01	

UNLESS OTHERWISE SPECIFIED:
 3RD ANGLE PROJECTION
 DIMENSIONS ARE IN INCHES
 TOLERANCES:
 ANGULAR ± 1°
 FRACTIONAL ± .025
 TWO PLACE DECIMAL ± .010
 THREE PLACE DECIMAL ± .006

MODEL:
 SMR-4-500 series

VibraSystems Inc

www.vibrasystems.com

PART: Spring Mount Restrained
 3" Deflection
 SMR-4-500

SIZE DWG. NO. REV
A 118-31-00-C **C**

SCALE: 1:7 DO NOT SCALE DRAWING SHEET 1 OF 1