

Installation Instructions for SMRT-1-500 (Top Bolt) - 3" Deflection spring

1) Check each spring mount's model number before installation. Position each spring mount according to the submittal drawings or the equipment's load distribution chart.

2) Secure each spring mount to the equipment support structure or concrete foundation using the four mounting holes on the bottom frame (BF). All bolts and anchor hardware must be a minimum of grade 5. If the engineering consulting agency or installation engineer recommends a higher grade of hardware, follow their recommendation. If spring mounts are welded in position, remove the rubber pad (RP) before welding (see figure 1).

3) Use a forklift, crane, or any other certified lifting machine to raise the equipment to be installed. Slowly lower the equipment on top of the spring mounts' top plates (TP) and ensure that the equipment's mounting holes are perfectly aligned with the spring mount's top plate's (TP) center threaded hole (see figure 1).

4) When the equipment is resting on top of all the spring mounts, the top plate nuts (TN) will rest on top of the bottom frame (BF), and gap #1 will disappear. Loosen all restraining nuts (RN) to the end of the threaded rods (TR) to allow leveling (see figure 1).

5) Screw the leveling bolts (LB) into the center threaded hole of the top plate (TP) of each spring mount. Turn the leveling bolts clockwise until they sit inside the thrust bolts' (TB) pockets, as shown in Figure 2.

6) Start leveling by turning all leveling bolts (LB) until gap #1 appears (approximately 3/16" to 1/4"), as shown in Figure 1.

7) Under rated load, the dimension 'C' should be approximately 6 inches, as shown in Figure 1

8) Proceed to fine-level each spring mount by turning the levelling bolt (LB), as shown in Figure 2.

9) After the equipment's leveling is complete, run down the lock nut (LN) with washers (W) and tighten them onto the equipment's base, as shown in Figure 2.

10) Adjust and lock the restraining nuts (RN) together, leaving a gap #2 of 3/16" to 1/4" clearance, as shown in Figure 1.

11) Every spring mount **must** have clearances at both gap #1 and gap #2 after the installation is complete, as detailed in Figure 1, detail B.

Note: We recommend using professional millwrights for the installation.

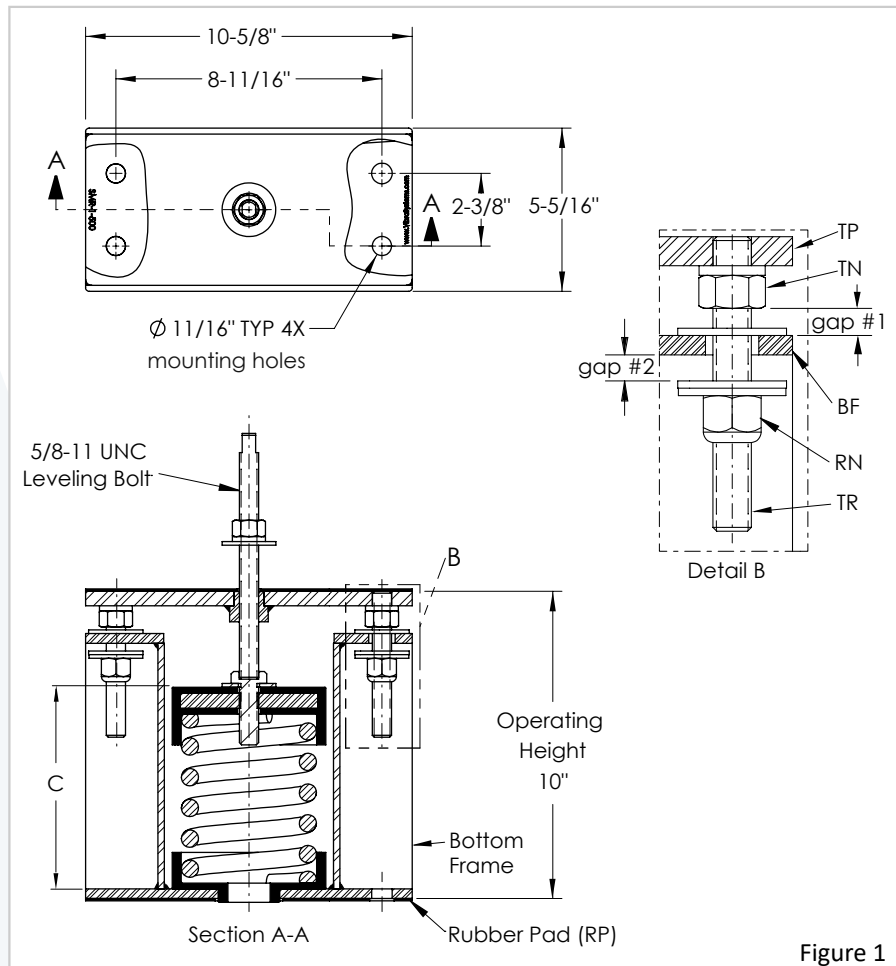
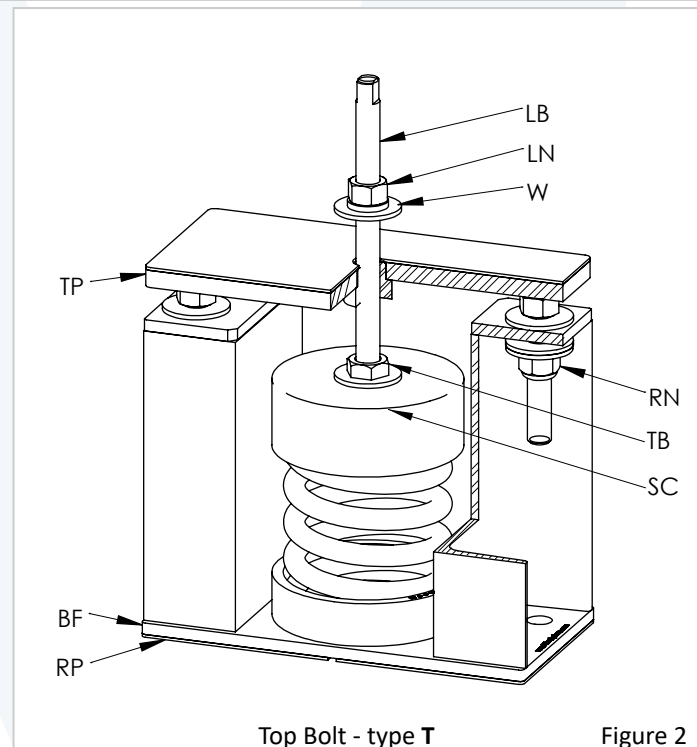

Figure 1



Top Bolt - type T

Figure 2