

Model	Pipe size, (in)	Dimensions, (in)			Ship. Weight (lbs)	Qty.
		A	B	C		
PS-2	2	3.00	3.63	4.75	10	
PS-2.5	2 1/2	3.50	4.13	5.50	10	
PS-3	3	3.75	4.63	6.00	12	
DPS-2	2	3.00	3.63	4.75	20	
DPS-2.5	2 1/2	3.50	4.13	5.50	20	
DPS-3	3	3.75	4.63	6.00	24	

PS - models

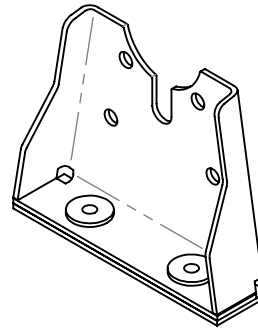

DPS - models

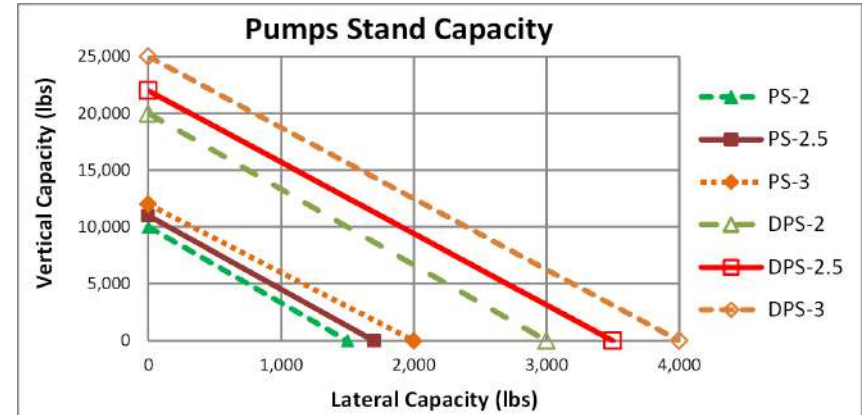
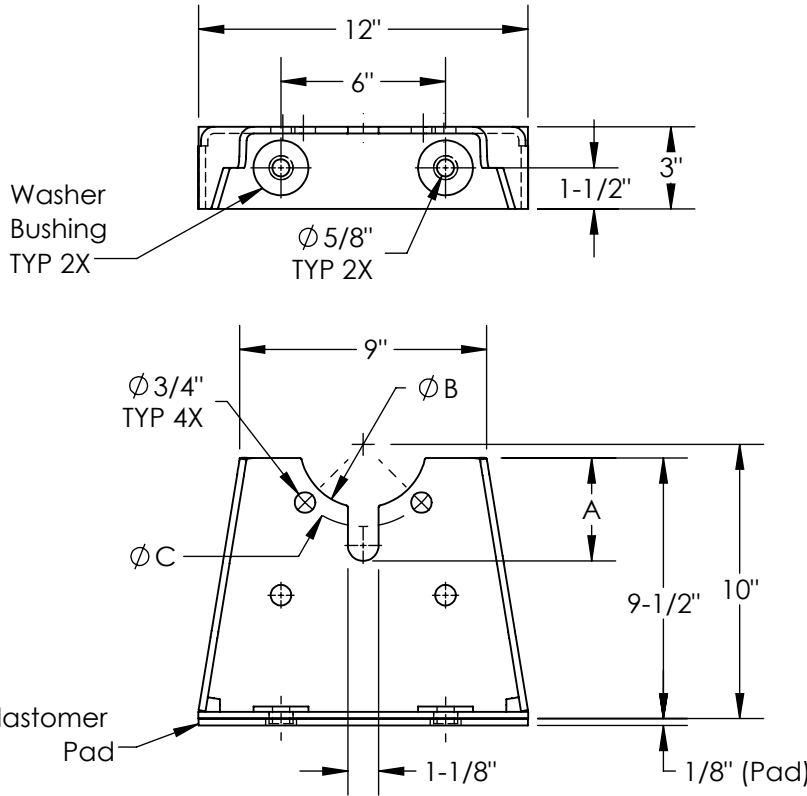
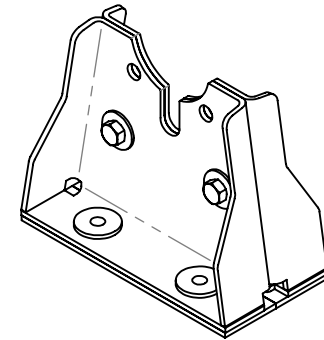

Notes:

1. Bolt holes and cutouts are sized to match ANSI 125 cast iron flange dimensions.
2. Elastomer Pad reduces minor vibration while Bridge-Bearing Neoprene Washer Bushings prevents metal to metal contact.
3. Pump Stands are made from rugged steel and painted for corrosion protection.
4. DPS consists of two PS Pump Stands bolted together; thus, the structural rigidity is increased.
5. Pump Stands must be installed in pairs for in-line pumps (see installation instructions).

NAME	DATE
DRAWN R.D.	2023-07-11
APPR. --	--
QUANTITY	01
UNLESS OTHERWISE SPECIFIED: 3RD ANGLE PROJECTION DIMENSIONS ARE IN INCHES TOLERANCES: ANGULAR ± 1° FRACTIONAL ± .025 TWO PLACE DECIMAL ± .010 THREE PLACE DECIMAL ± .006	
MODEL:	PS & DPS

VibraSystems Inc

www.vibrasystems.com

PART:

Submittal - Pump Stand
2" to 3" Pipe Size

SIZE

A

DWG. NO.

84-100-00-D

REV

D

SCALE: 1:7

DO NOT SCALE DRAWING

SHEET 1 OF 1