

## FLEXIBLE SANDWICH MOUNTS

**FSM mount** is a versatile anti-vibration channel mount. This configuration allows the top and bottom plates to be drilled anywhere along their length. The steel plates are bonded together with oil-resistant neoprene elastomer.

### Recommended for:

Wall and ceiling installations where a channel can be used as a mounting rail. Small-cut blocks can be used as individual isolators.



### Features:

- ✓ Effectively isolates against horizontal, vertical, and shock forces.
- ✓ Low installation height.
- ✓ Superior ability to withstand shear load with low horizontal deflection.
- ✓ Neoprene on top of the channel provides a firm grip for mounting and avoids metal to metal contact.

Model	Load per Linear-inch (lbs/in)	Length L	Width W	Dimensions in inches (in)					Shipping Weight (lbs)
				Height H	A	B	C	D	
FSM-12	50	12	4-1/2	1-5/16	3/4	1-1/2	1	2-3/4	3
FSM-24	50	24	4-1/2	1-5/16	3/4	1-1/2	1	2-3/4	6
FSM-48	50	48	4-1/2	1-5/16	3/4	1-1/2	1	2-3/4	12
FSM-60	50	60	4-1/2	1-5/16	3/4	1-1/2	1	2-3/4	16

Load Vs Deflection Chart

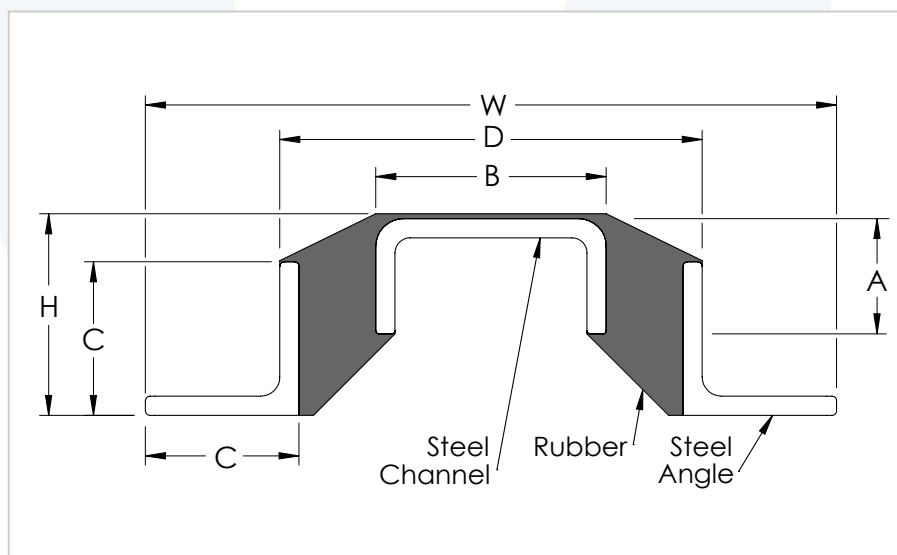
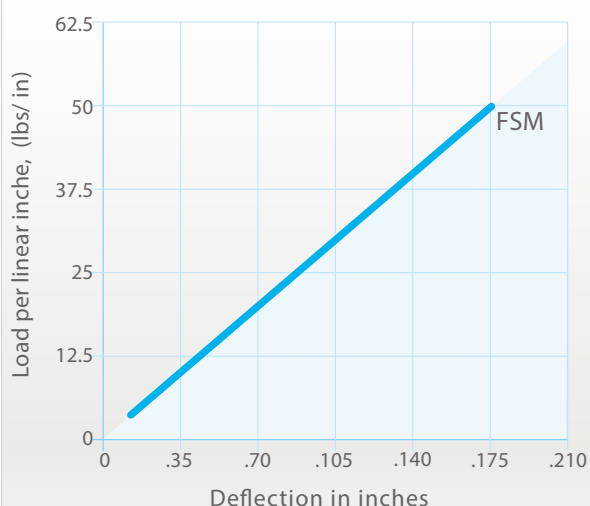

### Custom Options:

- \* Material: Plates can be made of Aluminum, or stainless steel. Other elastomer materials/compounds available upon request.
- \* Available in custom cut length of 2" increments.
- \* Bars can be welded to steel bases of any design upon request.