

## WEDGE MOUNTS

**VWH wedge mounts** are designed for precise leveling of heavy industrial machinery, equipment and structures. Accurate leveling is achieved by three precision ground ductile iron wedges. Wedges are guided and provide stable, accurate leveling under heavy load. Three machined wedges are held together by a horizontal adjusting bolt. A lock screw secures the mount in the leveled position. Keys in the sliding surfaces of the wedges ensure rigid mount construction. A special opening allows for bolting of the machine to the floor.



### Recommended for:

Wedge mounts are commonly used on machines subject to high thrust that require a permanent connection to the machine bed, such as injection moulding machines, slotting machines, extrusion machines, CNC lathes, test equipment, grinding machines, rolling mills, etc.

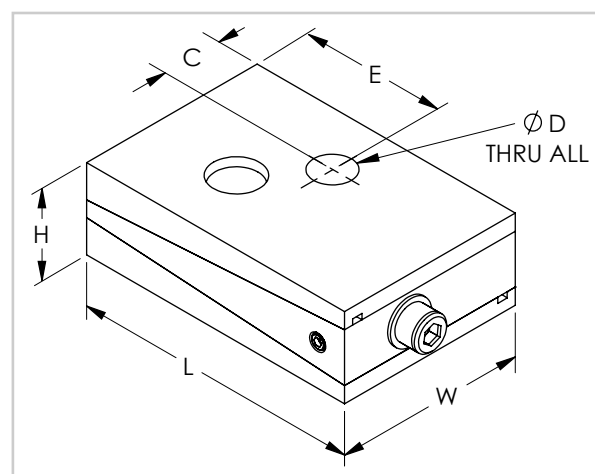
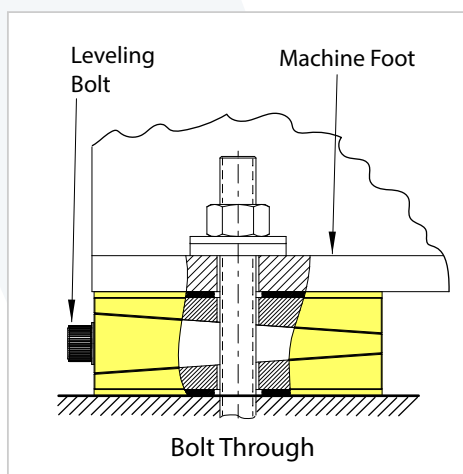
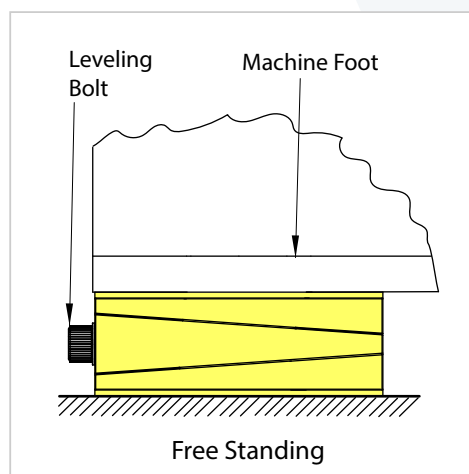

### Features:

- ✓ Optimal neoprene top and bottom pads. \*
- ✓ Precision leveling distance per turn:  
VWH-5 = .005 in/rev.    VWH-15 = .007 in/rev.
- ✓ Leveling range:  $\pm .100''$  (VWH-5) and  $\pm .150''$  (VWH-15)
- ✓ Mounts have a hole through ( $\varnothing D$ ) for anchoring machine to the floor in leveled position.

Model	Maximum Load (lbs)	Mount Dimensions in inches						Leveling H (in)
		L	W	H	C	E	D	
VWH-5	3,000	4.000	2.625	1.313	.813 $\pm$ .062	2 $\pm$ .062	.500 - .625	H $\pm$ .100
VWH-5R	3,000	4.000	2.625	1.500	.813 $\pm$ .062	2 $\pm$ .062	.500 - .625	H $\pm$ .100
VWH-15	8,000	6.000	4.000	1.875	1.25 $\pm$ .062	3 $\pm$ .062	.750 - .875	H $\pm$ .150
VWH-15R	8,000	6.000	4.000	2.275	1.25 $\pm$ .062	3 $\pm$ .062	.750 - .875	H $\pm$ .150

### Notes:

- 1) VWH-5 can be used with standard M12 connecting bolt or shoulder bolt.
- 2) VWH-15 can be used with standard M18 connecting bolt or shoulder bolt.
- 3) Models VWH-5R & VWH-15R come with top and bottom glued rubber pads. \*
- 4) Unless otherwise specified, general tolerances are  $\pm .125$  inches.